

Ürün FM Kodu	Ürün Kodu	Tanımı
KMKBYF	KM100 - KBFM	Kardan Mafsallı Deprem Kompansatörleri FM Onaylı Kaynak Boyunlu ± 50 mm Genleşmeli
KMKBYF	KM200 - KBFM	Kardan Mafsallı Deprem Kompansatörleri FM Onaylı Kaynak Boyunlu ± 100 mm Genleşmeli
KMKBYF	KM300 - KBFM	Kardan Mafsallı Deprem Kompansatörleri FM Onaylı Kaynak Boyunlu ± 150 mm Genleşmeli
KMKBYF	KM400 - KBFM	Kardan Mafsallı Deprem Kompansatörleri FM Onaylı Kaynak Boyunlu ± 200 mm Genleşmeli

GENEL

Kardan mafsallı deprem kompansatörleri; üç boyuttaki hareketi eksenel, yanal ve açısız olarak sönümleyerek sismik (Deprem, bina çökmeleri vb.) hareketler sonucu sistemde oluşabilecek kırılma riskini minimuma indiren, rijit boru üzerindeki stresi olarak sistemin devamlılığını sağlayan esnek bağlantı elemanlarıdır. Üç farklı yönde (eksenel, yanal ve açısız) hareketi karşılayabilecek şekilde dizayn edilen Kardan Mafsallı Deprem Kompansatörleri FM onaylı olduğu için özellikle yangın devrelerinde yaygın olarak kullanılırlar. Ayrıca tüm bina geçişleri, Dilatasyon noktaları vb. yerlerde de kullanılırlar.

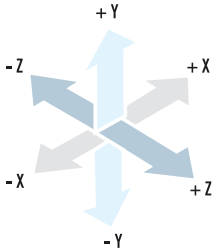

Standart Ürün Malzemeleri		Opsiyonel Ürün Malzemeleri	
Körük	1.4301 (AISI 304)	1.4541 / 1.4401 / Titanyum / Incoloy 800H / Inconel vb.	
Mafsallar	1.0038 (St 37-2)	Paslanmaz Çelik	
Kaynak Boyunlar	1.0038 (St 37-2)	Paslanmaz Çelik	
Ara Boru	1.0038 (St 37-2)	Paslanmaz Çelik	

Dizayn Parametreleri	
Dizayn Basıncı	250 psi
Dizayn Sıcaklığı	+20 °C (-90°C...+550°C)
Bağlantı Çapları	DN25 (1")...DN300 (12")
Genleşme Miktarları	X: ± 50 mm ; Y,Z: ± 50 mm / Y,Z: ± 100 mm / Y,Z: ± 150 mm / Y,Z: ± 200 mm
Dizayn Standartları	EJMA, EN 14917
Sertifikalar	FM Approved - TSE - CE Modül H (Opsiyonel) - EAC

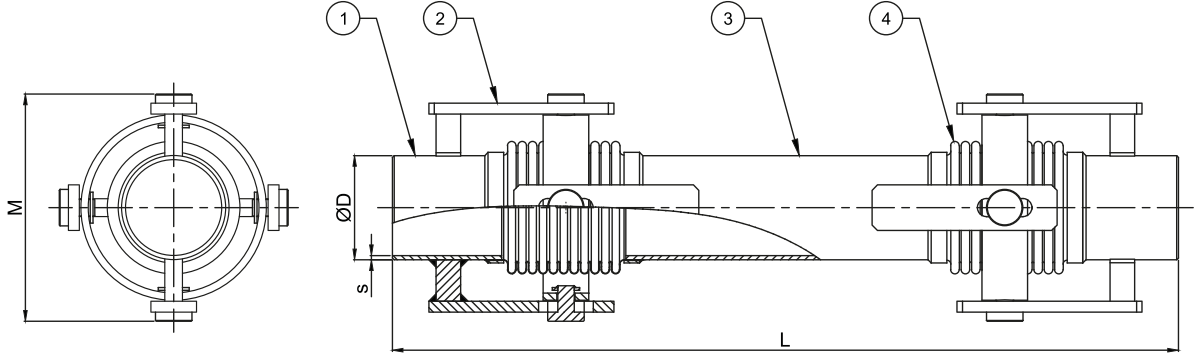

Parça Numarası	Özellikler	
	Parça Adı	Malzeme
1	Kaynak Boynu	1.0038 (S235JR / St37-2)
2	Mafsall Kolu	1.0038 (S235JR / St37-2)
3	Ara Boru	1.0038 (S235JR / St37-2)
4	Körük	1.4301 (AISI 304)

Bağlantı Çapı	BOY (L = mm)				ØD (mm)	s (mm)	M (mm)	Efektif Alan (cm ²)	
	KMKBYF								
	KM100-KBFM	KM200-KBFM	KM300-KBFM	KM400-KBFM					
DN25	1"	710	910	1110	1310	33,7	3,2	160	19,0
DN32	1 1/4"	710	910	1110	1310	42,4	3,2	160	19,0
DN40	1 1/2"	710	910	1110	1310	48,3	3,2	160	24,7
DN50	2"	770	970	1170	1380	60,3	3,6	185	38,7
DN65	2 1/2"	770	970	1220	1480	76,1	3,6	205	58,0
DN80	3"	820	1020	1250	1480	88,9	4	215	80,5
DN100	4"	820	1020	1280	1530	114,3	4,5	280	129,0
DN125	5"	950	1150	1460	1750	139,7	5	335	191,8
DN150	6"	950	1150	1460	1750	165,1	5	345	262,7
DN200	8"	1120	1340	1690	2040	219,1	6,3	435	453,5
DN250	10"	1120	1340	1690	2040	273	6,3	495	698,4
DN300	12"	1150	1525	1900	2265	323,9	7,1	565	967,0

** X,Y,Z değerleri genişleme miktarlarını temsil etmektedir. Farklı genişleme değerleri için satış ekibimize irtibata geçiniz.

FM Code	Product Code	Definition
KMKBYF	KM100 - KBFM	Dilatation & Earthquake Expansion Joint FM Approved Welding Ends ± 50 mm Expansion
KMKBYF	KM200 - KBFM	Dilatation & Earthquake Expansion Joint FM Approved Welding Ends ± 100 mm Expansion
KMKBYF	KM300 - KBFM	Dilatation & Earthquake Expansion Joint FM Approved Welding Ends ± 150 mm Expansion
KMKBYF	KM400 - KBFM	Dilatation & Earthquake Expansion Joint FM Approved Welding Ends ± 200 mm Expansion

GENERAL

Dilatation & Earthquake expansion joints are the flexible connection elements that minimize the risk of breakage that may occur in the system as a result of seismic (earthquake, building collapses, etc.) movements by damping the three dimensional movement as axial, lateral and angular and provide the continuity of the system by removing the stress on the rigid pipe. The Dilatation & Earthquake Expansion joints, which are designed to meet the movement in three different directions (axial, lateral and angular) are widely used in fire circuits since they are FM approved. They can also be used in places such as all building passages, Dilatation points etc.

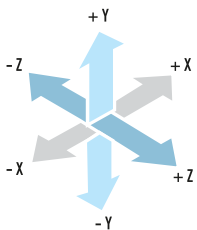

Standard Product Materials		Optional Product Materials
Bellows	1.4301 (AISI 304)	1.4541 / 1.4401 / Titanium / Incoloy 800H / Inconel etc.
Joint Arms	1.0038 (St 37-2)	Stainless Steel
Welding Ends	1.0038 (St 37-2)	Stainless Steel
Intermediate Pipe	1.0038 (St 37-2)	Stainless Steel

Design Parameters	
Design Pressure	250 psi
Design Temperature	+20°C (-90°C...+550°C)
Diameters	DN25 (1")...DN300 (12")
Movements	X: ± 50 mm ; Y,Z: ± 50 mm / Y,Z: ± 100 mm / Y,Z: ± 150 mm / Y,Z: ± 200 mm
Standards	EJMA, EN 14917
Certifications	FM Approved - TSE - CE Module H (Optional) - EAC

**Please contact our sales team for your special requests.

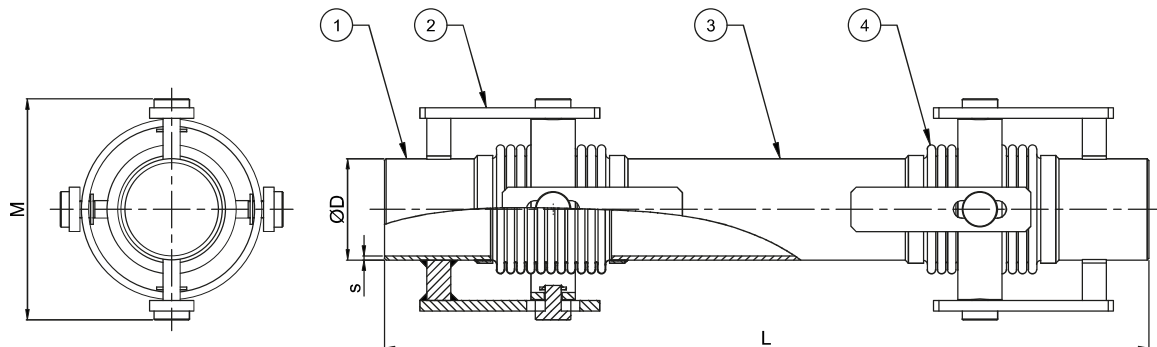

Part Number	Specifications	
	Name	Material
1	Welding Ends	1.0038 (S235JR / St37-2)
2	Joint Arm	1.0038 (S235JR / St37-2)
3	Intermediate Pipe	1.0038 (S235JR / St37-2)
4	Bellows	1.4301 (AISI 304)

Diameters		LENGTH (L = mm)				ØD (mm)	s (mm)	M (mm)	Effective Area (cm ²)
		KMKBYF							
		KM100-KBFM	KM200-KBFM	KM300-KBFM	KM400-KBFM				
		X: ±50mm Y: ±50mm Z: ±50mm	X: ±50mm Y: ±100mm Z: ±100mm	X: ±50mm Y: ±150mm Z: ±150mm	X: ±50mm Y: ±200mm Z: ±200mm				
DN25	1"	710	910	1110	1310	33,7	3,2	160	19,0
DN32	1 1/4"	710	910	1110	1310	42,4	3,2	160	19,0
DN40	1 1/2"	710	910	1110	1310	48,3	3,2	160	24,7
DN50	2"	770	970	1170	1380	60,3	3,6	185	38,7
DN65	2 1/2"	770	970	1220	1480	76,1	3,6	205	58,0
DN80	3"	820	1020	1250	1480	88,9	4	215	80,5
DN100	4"	820	1020	1280	1530	114,3	4,5	280	129,0
DN125	5"	950	1150	1460	1750	139,7	5	335	191,8
DN150	6"	950	1150	1460	1750	165,1	5	345	262,7
DN200	8"	1120	1340	1690	2040	219,1	6,3	435	453,5
DN250	10"	1120	1340	1690	2040	273	6,3	495	698,4
DN300	12"	1150	1525	1900	2265	323,9	7,1	565	967,0

** X,Y,Z value represents axial, lateral, angular movements. Please contact our technical department for different movement requirements.